

E700 Series 3 1/4" Frame Depth Horizontal Slider

E700 SERIES HORIZONTAL SLIDER

FEATURES

- ◇ **Commercial Framing System**
 - 3 1/4" main frame
 - 0.062" wall thickness of frame
- ◇ **Thermally Enhanced Design**
 - Azon pour and debridge thermal break is 1/2" wide in all main frame and vent rail extrusions
 - Frame and sash mitered and joined with screw fasteners
 - Fin seal wool pile weatherstripping
 - Positive interlocks
- ◇ **Glazing**
 - Impact-rated glazing package
- ◇ **Hardware**
 - Brass rollers with stainless steel axle pins for easy operation
 - Gravity latch
- ◇ **Screen**
 - Extruded aluminum screen frame with BetterVue™ mesh with Watershed® Technology

OPTIONS

- ◇ **Available Configurations**
 - Fixed-Active
 - Active-Fixed
 - Active-Fixed-Active
 - Fixed-Active-Fixed
- ◇ **Muntin Choices**
 - Internal or simulated divided lites available
- ◇ **Hardware**
 - Sweep lock
 - Night latch
 - Limited travel latch
 - Wide variety of locking and operating hardware options
- ◇ **Nailing Fin**
- ◇ **Screen**
 - Extruded aluminum screen frame with aluminum wire mesh
 - Extruded aluminum screen frame with sunscreen mesh
 - Extruded aluminum screen frame with stainless steel 0.009" thickness mesh
 - Security screen (limitations apply)
- ◇ **Glazing**
 - Multiple Low-E and argon glazing choices
 - Capillary tubes
 - Wide variety of glazing, tinting and thickness options
- ◇ **Panning & Trim Choices**
 - Wide variety of panning, receptor and trim available

BENEFITS

- ◇ Meets ASTM 1886 (Large Missile Impact testing)
- ◇ The capacity to match exterior colors for unique project facades
- ◇ The ability to facilitate large sizes for taller and wider window openings

PERFORMANCE

- ◇ Structural & Thermal (test reports or thermal simulations available upon request)

Model	Horizontal Slider
NAFS Rating	AW-PG50
Structural Load P.S.F.	75.19
Air Infiltration	<0.10
Water (No Penetration) P.S.F.	10.03
U-Value (with Low-E and Argon)	
SHGC (with Low-E and Argon)	

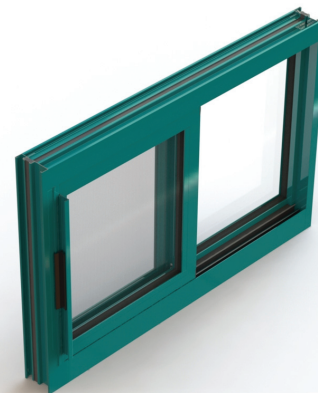

Window test size: 72" x 66"

Operating Force: 22 lbf (maintain motion), 1 lbf (latches)

Our products are tested to the standards of and certified by some of the foremost organizations in the fenestration industry.





E700 Series 3 1/4" Frame Depth Horizontal Slider

E700 SERIES SLIDER WITH NAILING FIN

This document contains confidential and proprietary information intended for the private use of Quaker.
 © 2016 Quaker Window Products Co., INC. All rights reserved.
 Quaker reserves the right to change any/all designs without notice. Due to periodic re-certification requirements, result shown may vary.

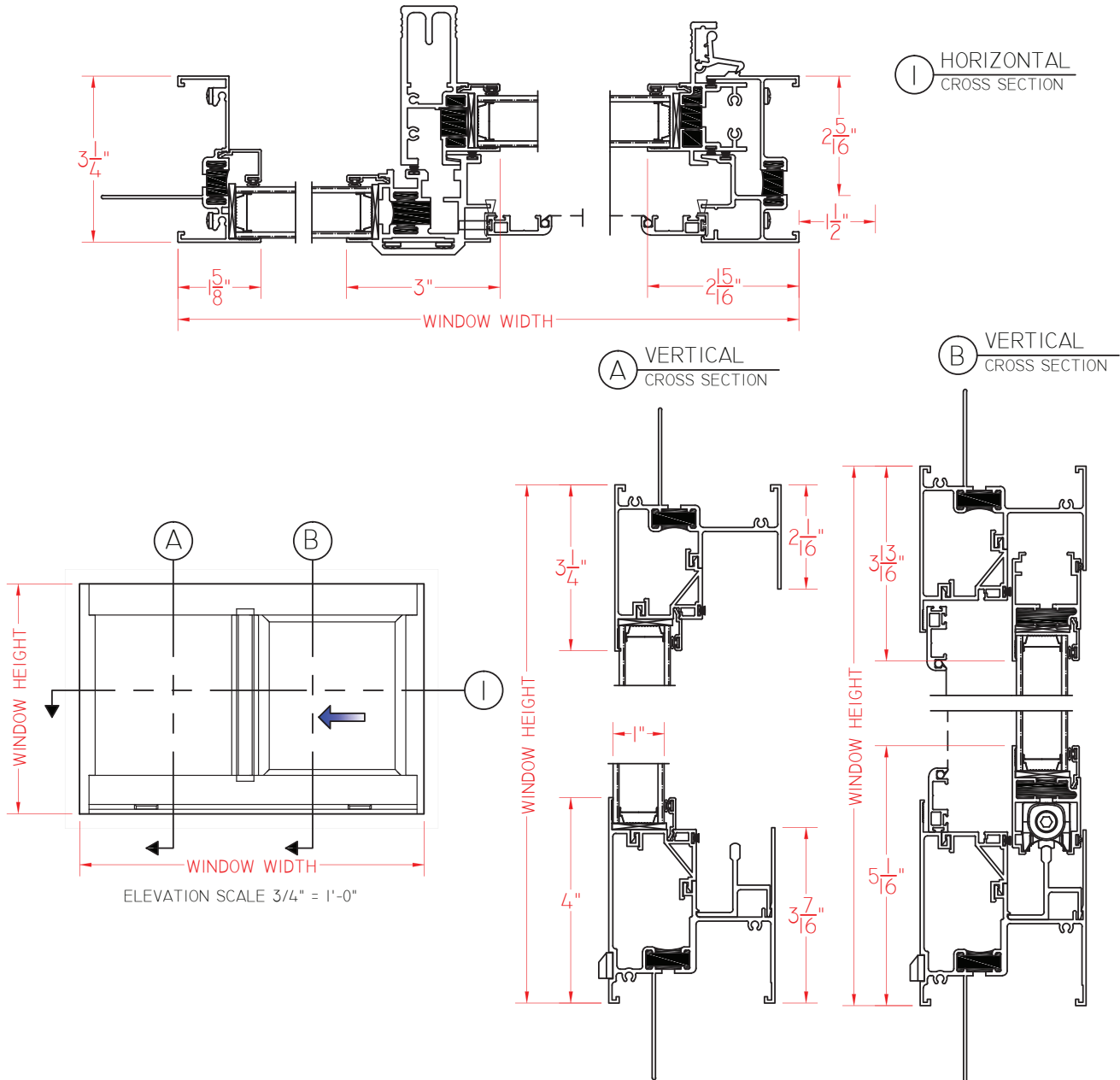

SCALE 1:3

Our products are tested to the standards of and certified by some of the foremost organizations in the fenestration industry.





E700 Series
3 1/4" Frame Depth
Horizontal Slider

E700 SERIES SLIDER WITHOUT NAILING FIN

This document contains confidential and proprietary information intended for the private use of Quaker.
© 2016 Quaker Window Products Co., INC. All rights reserved.
Quaker reserves the right to change any/all designs without notice. Due to periodic re-certification requirements, result shown may vary.

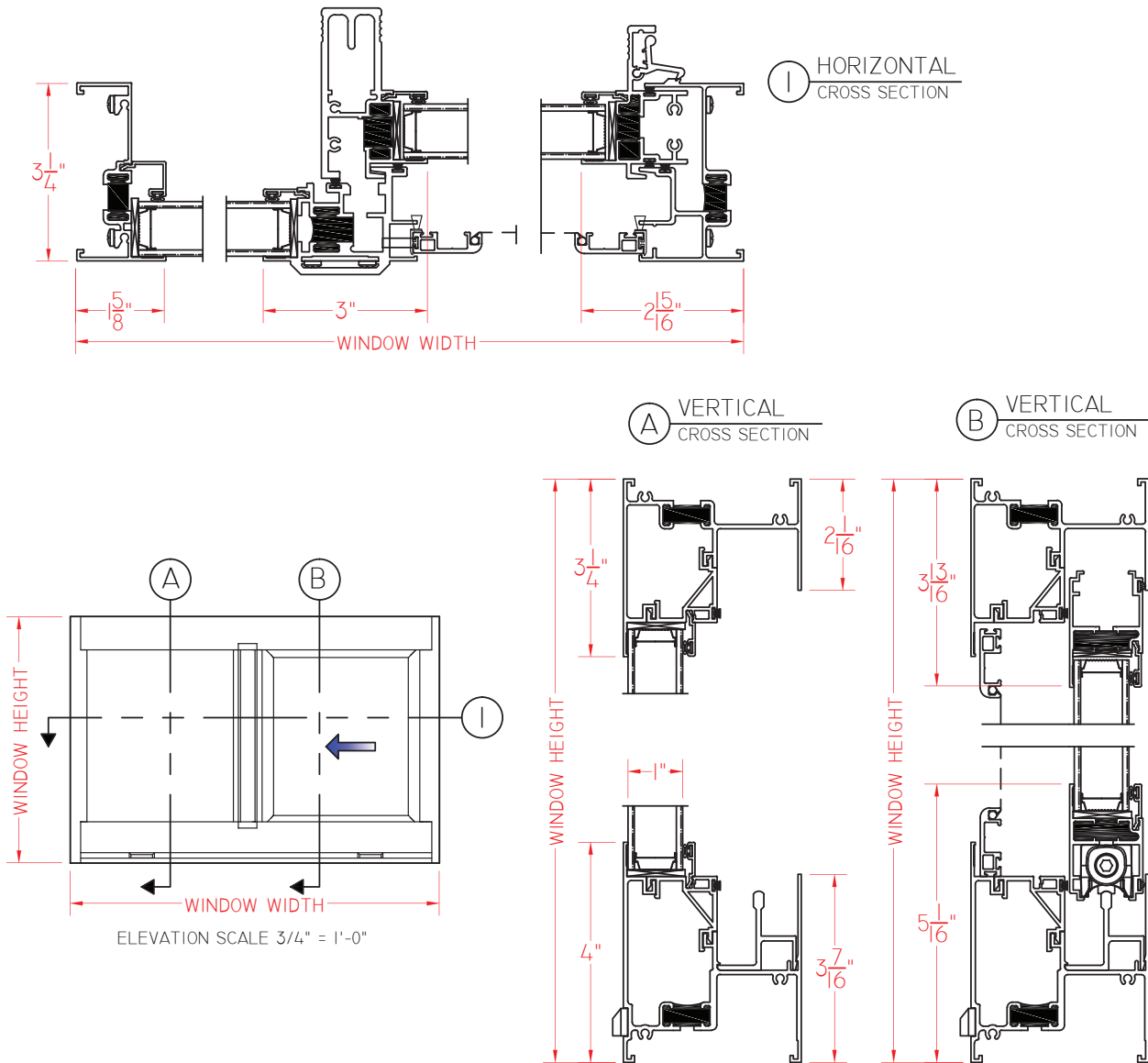

SCALE 1:3

Our products are tested to the standards of and certified by some of the foremost organizations in the fenestration industry.



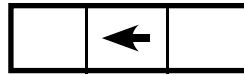

E700 Series 3 1/4" Frame Depth Horizontal Slider

E700 SERIES CENTER VENT SLIDER WITH NAILING FIN

This document contains confidential and proprietary information intended for the private use of Quaker.
© 2016 Quaker Window Products Co., INC. All rights reserved.
Quaker reserves the right to change any/all designs without notice. Due to periodic re-certification requirements, result shown may vary.

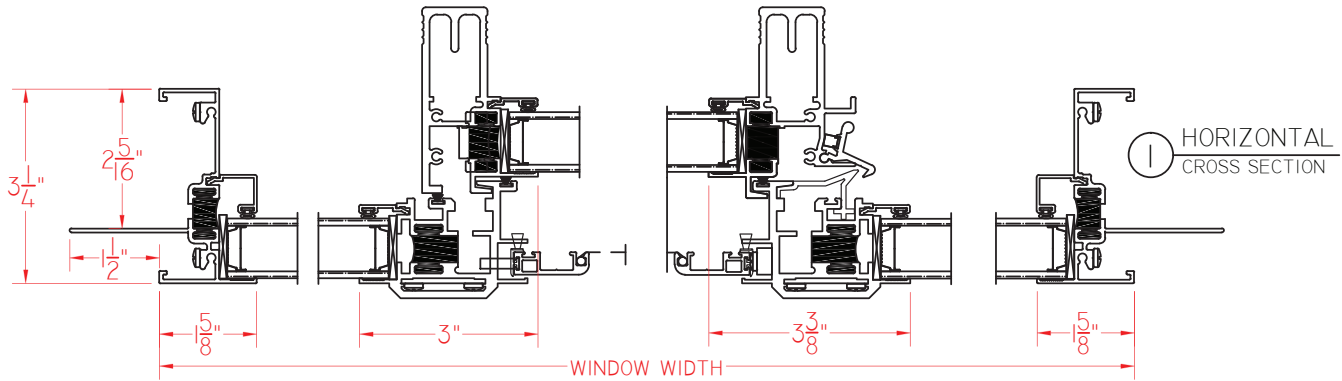

① A VERTICAL CROSS SECTION

① B VERTICAL CROSS SECTION

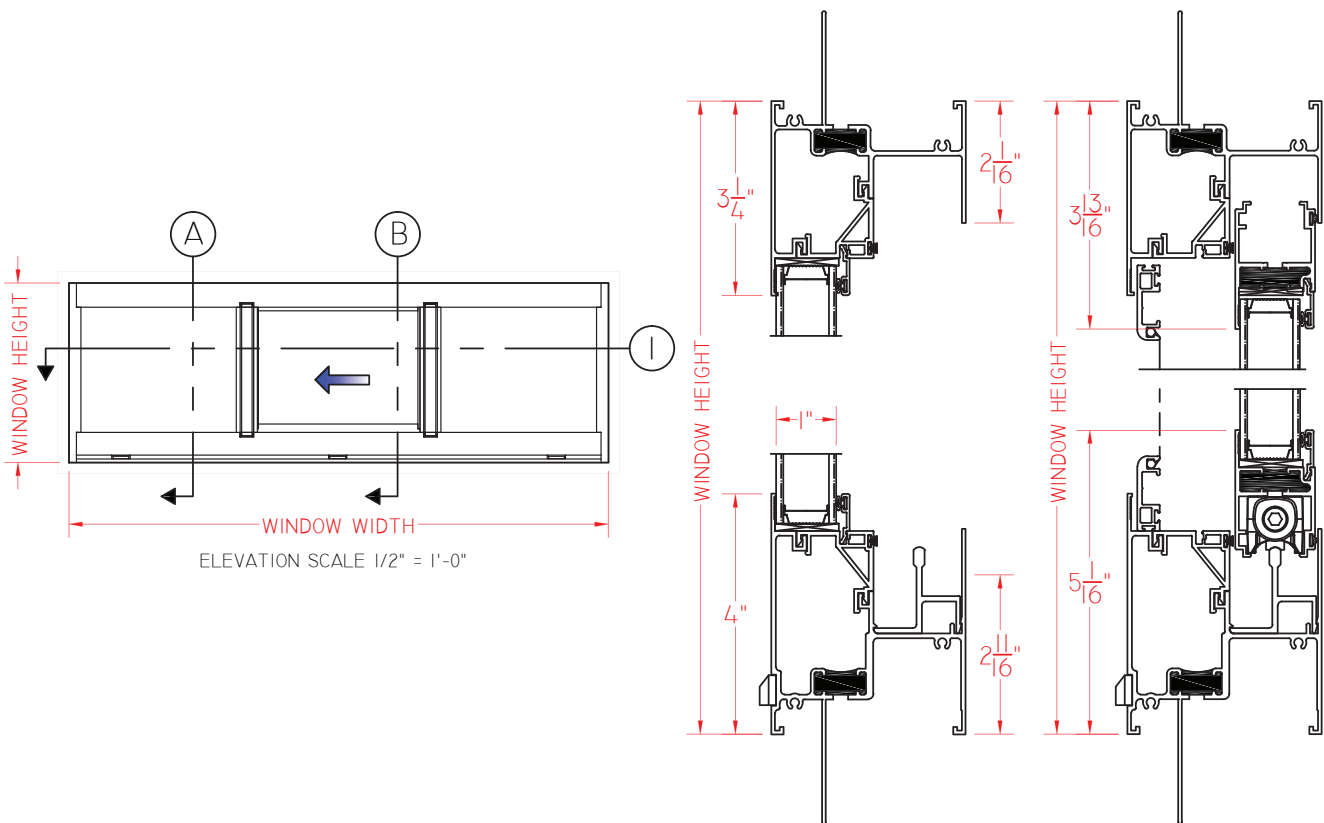

SCALE 1:3

Our products are tested to the standards of and certified by some of the foremost organizations in the fenestration industry.



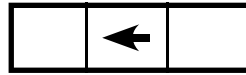

E700 Series
3 1/4" Frame Depth
Horizontal Slider

E700 SERIES CENTER VENT SLIDER WITHOUT NAILING FIN

This document contains confidential and proprietary information intended for the private use of Quaker.
© 2016 Quaker Window Products Co., INC. All rights reserved.
Quaker reserves the right to change any/all designs without notice. Due to periodic re-certification requirements, result shown may vary.

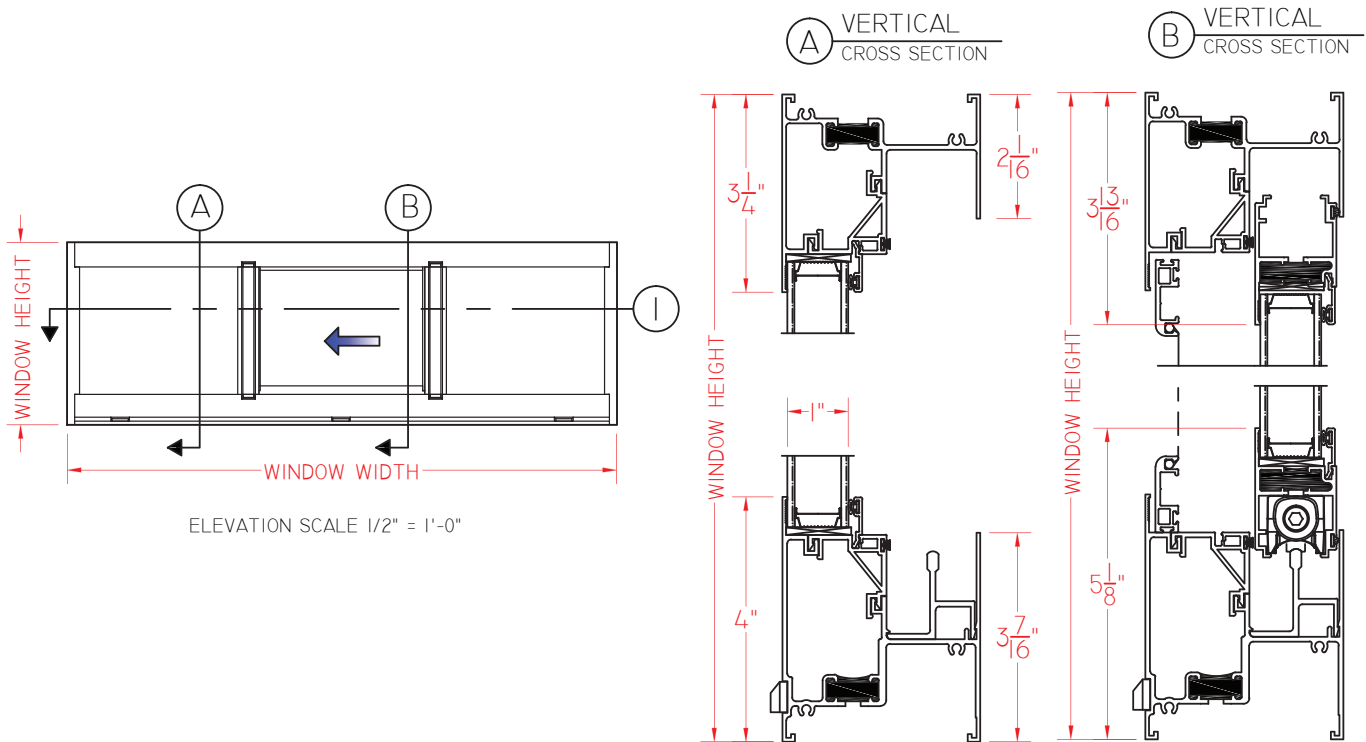
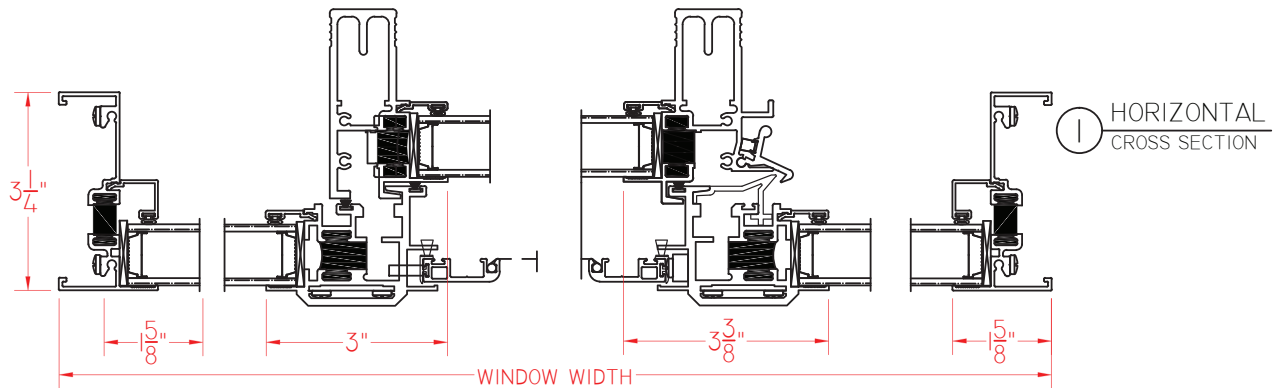

SCALE 1:3



E700 Series
3 1/4" Frame Depth
Horizontal Slider

E700 SERIES END VENT SLIDER WITH NAILING FIN

This document contains confidential and proprietary information intended for the private use of Quaker.
© 2016 Quaker Window Products Co., INC. All rights reserved.
Quaker reserves the right to change any/all designs without notice. Due to periodic re-certification requirements, result shown may vary.

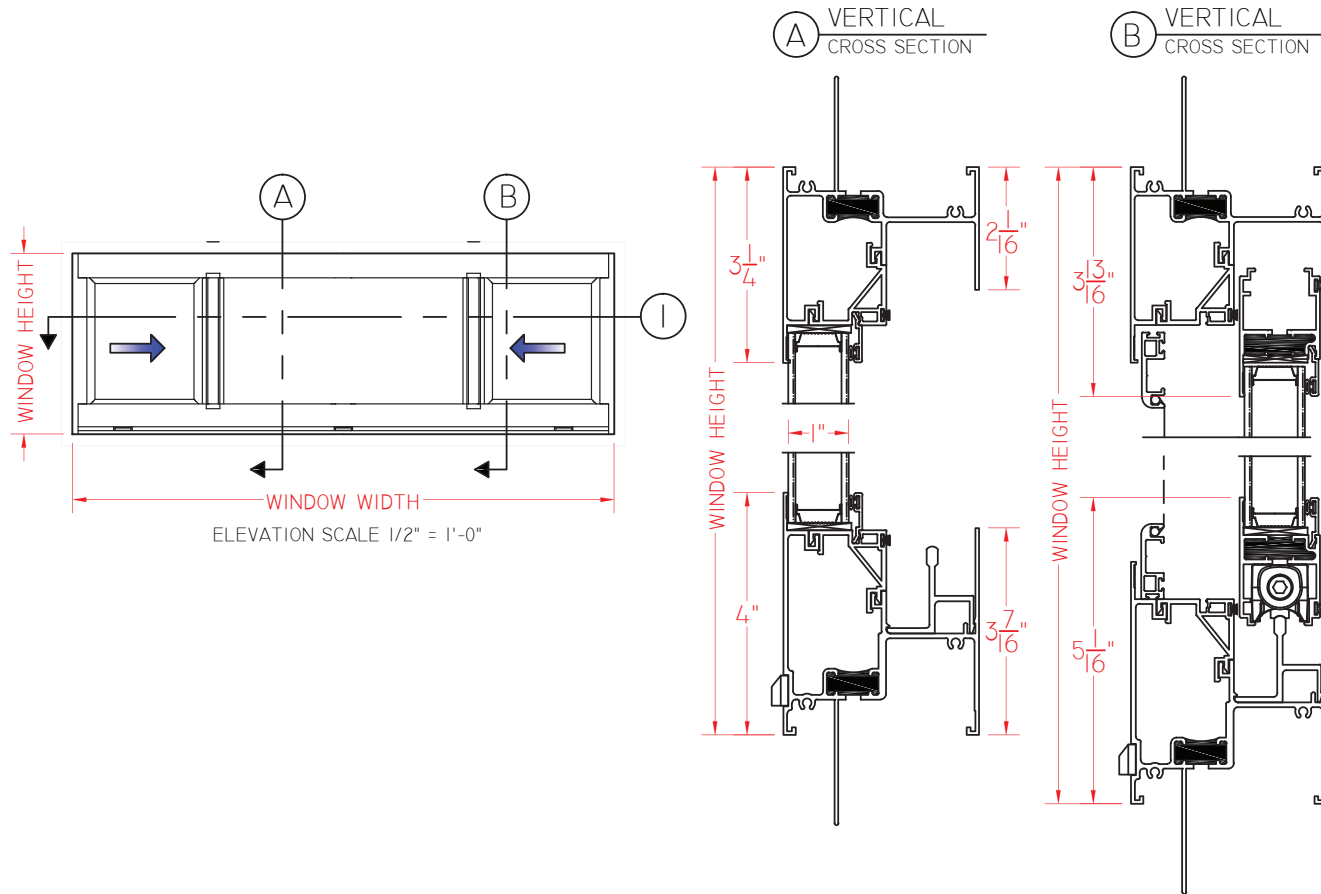
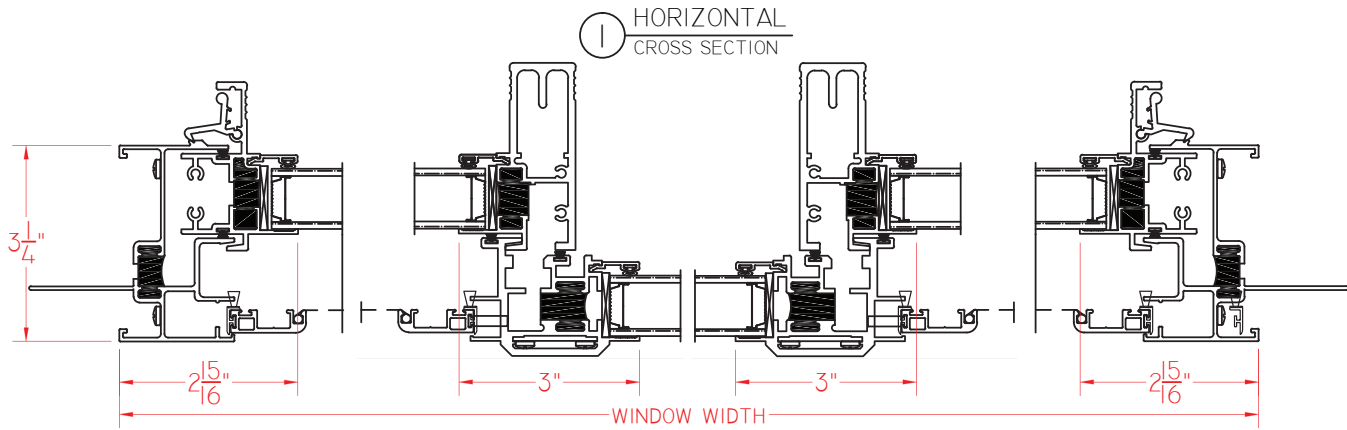

SCALE 1:3

Our products are tested to the standards of and certified by some of the foremost organizations in the fenestration industry.





E700 Series
3 1/4" Frame Depth
Horizontal Slider

E700 SERIES END VENT SLIDER WITHOUT NAILING FIN

This document contains confidential and proprietary information intended for the private use of Quaker.
© 2016 Quaker Window Products Co., INC. All rights reserved.
Quaker reserves the right to change any/all designs without notice. Due to periodic re-certification requirements, result shown may vary.

① HORIZONTAL
CROSS SECTION

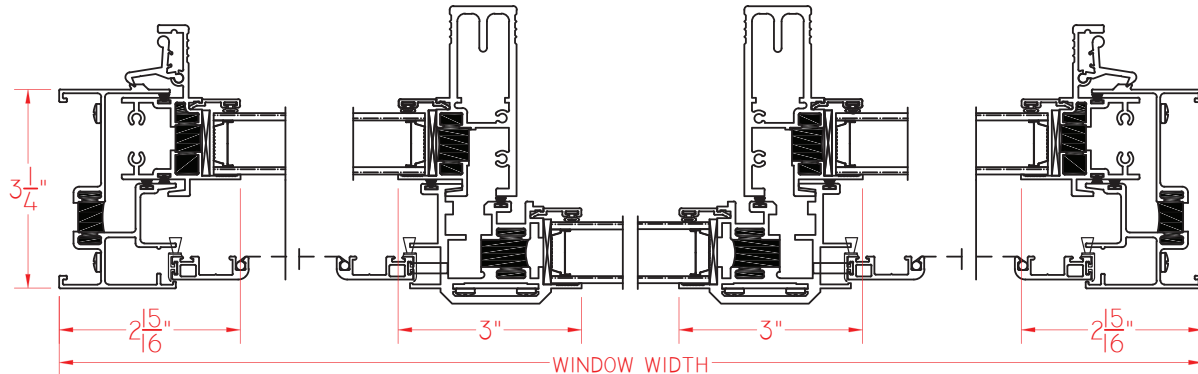

④ A VERTICAL
CROSS SECTION

④ B VERTICAL
CROSS SECTION

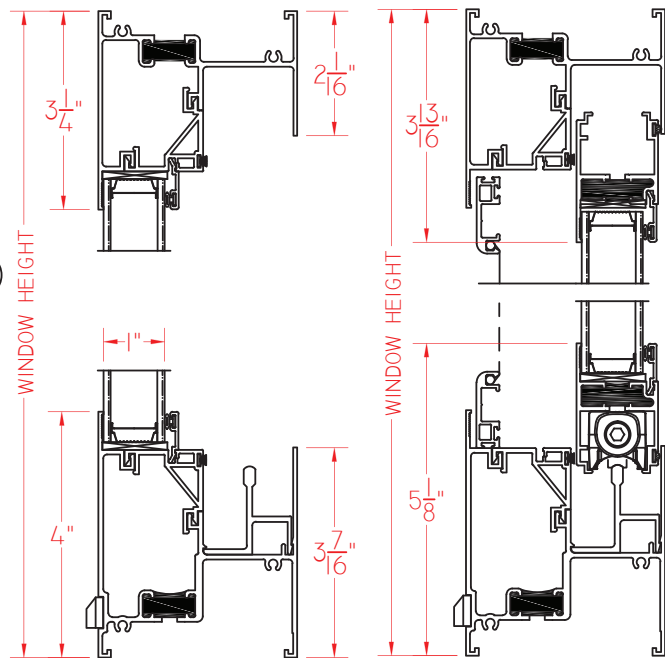
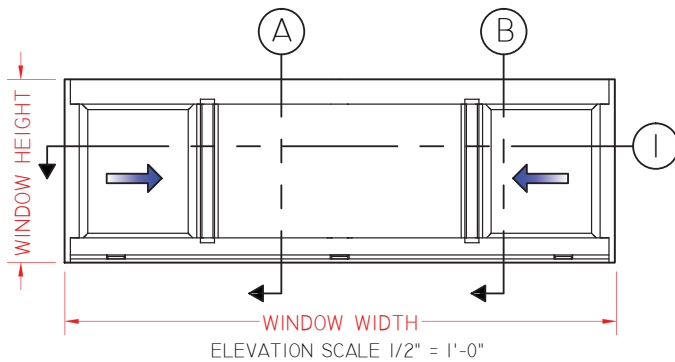

SCALE 1:3